

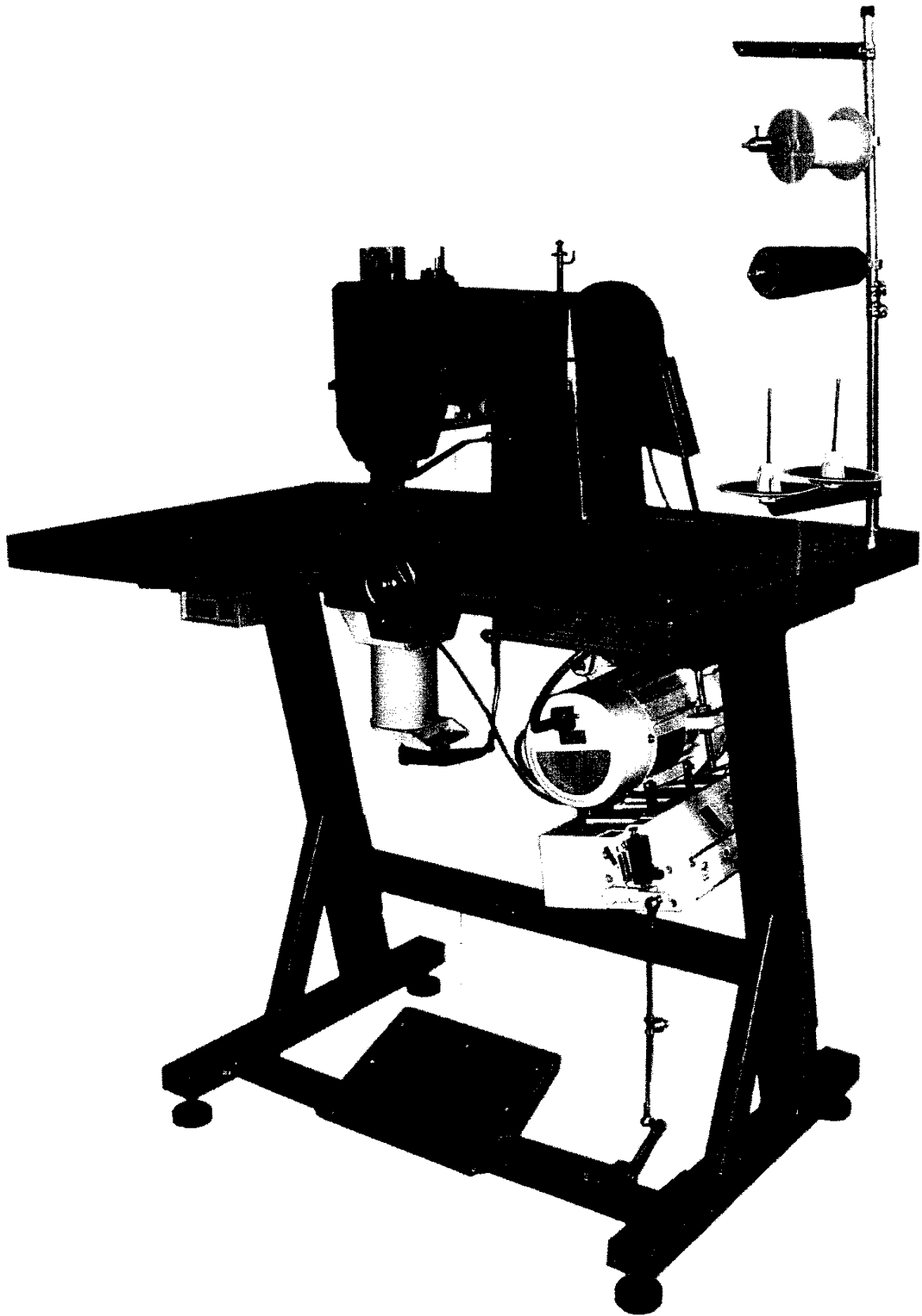

*OS 7200 DOUBLE NEEDLE LEVEL  
SEWING MACHINE*

**OPERATING  
INSTRUCTION MANUAL**

**SERIAL NO. : \_\_\_\_\_**



# CONTENT

1. MACHINE DESCRIPTION .....	1
2. TECHNICAL FEATURES OF OS 7200 .....	1
3. PREPARATION OF THE MACHINE READY FOR USE .....	1
3.1 Fix the needles .....	1
3.2 Needle thread preparation .....	2
4. USE OF THE MACHINE .....	2
4.1 Start pedal .....	2
4.2 Stitching length adjustment setting .....	2
4.3 Tension adjustment setting of needle thread .....	2
4.4 Height adjustment setting of presser wheel .....	3
4.5 Pressure adjustment setting of presser wheel .....	3
5. REPLACEMENT AND ADJUSTMENT .....	3
5.1 Adjustment of distance between two needles .....	3
5.2 Setting stitching seam .....	4
5.3 Adjustment of setting shuttle-needle timing .....	6
5.4 Adjustment of setting tooth transport .....	6
5.5 Adjustment of setting needles intercross timing .....	7
5.6 Adjustment of setting the distance of the needle bar be pushed .....	7
5.7 Adjustment of stopping position .....	7
6. MAINTENANCE AND REPAIR .....	8
7. SPARE PARTS FOR THE SEWING MACHINE .....	8
8. PARTS SUPPLIED WITH THE MACHINE .....	8
 <b>PARTS DRAWIING</b> .....	 9

**Thank you very much for your choice of this double needle level sewing machine . Please read the manual carefully before use!**

## 1. MACHINE DESCRIPTION

OS 7200 is a double needle sewing machine.it is particularly suitable for seam stitching on uppers("open" uppers,tubular maccasin with insole cut) as well as on full skin,medium-heavy flesh split(suitcases,tool bags, travelling bags)and heavy fabric like jeans.

The operator can choose twelve kinds of stitching seams(six 1 needle programs and six 2 needle programs)according to the operator's requirement.

## 2. TECHNICAL FEATURES OF OS 7200

Sewing Speed:	Stepless speed regulating
Stitch Length:	0-10mm
Thread Diameter:	0.6-1.0mm
Sewing Needle:	DDX 1(160/180/200)
Motor:	550W/220V(Single-phase) or 550W/380V(Three-phase)
Net Weight:	170kg
Total Packed Weight:	200kg
Machine Dimensions:	97×68×122cm(L.× W.×H.)
Dimensions With Packing:	107×80×135cm (L. × W. × H. )

## 3. PREPARING THE MACHINE READY FOR UEE

### 3.1 Fix the needles( Fig 1)

To fix the needles , proceed as follows

- Turn the pulley(203) in the correct direction as shown on the belt cover by hand so that needle bar comes to its highest position(at this position the distance form the needle holder's(of the needle bar220/230) upper plane to the needle bar supporter's(223/228) below plane is 1.5mm)
- Insert the needles upto the bottom of needle hole and tighten the screws keeping the short groove is back against on to the operator

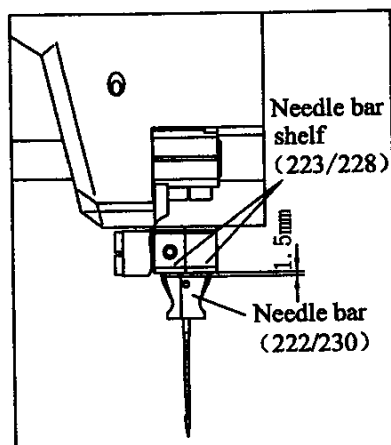

Fig 1

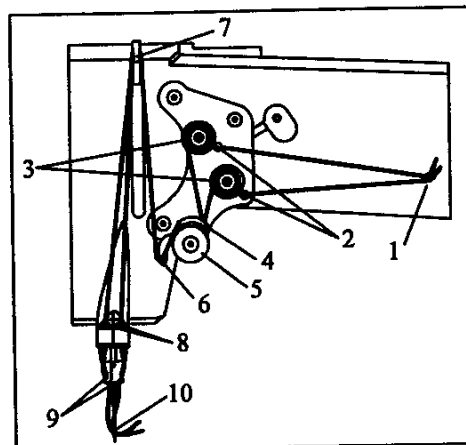

Fig 2

### 3.2 Needle thread preparation

To prepare the needle thread , proceed as follows

- Rotate the pulley (203) by hand until the needles come to its highest position
- Thread the needle thread by the path indicated in Fig 2

## 4. USE OF THE MACHINE

### 4.1 Start pedal

First of all ,switch on the machine to watch if the rotation of motor is conformable to the red arrow on the belt cover . If the direction is opposite , switch in the other way round. Then operate the pedal in three different movement(Fig 3)

- Stepping on forward (Position A) means advance. Stepping on lightly is slow and Stepping on heavily is fast. Avoid stepping on heavily at the very beginning.
- Stop in the neutral position
- Stepping on backward (Position B) means lifting the presser wheel(315) so that it is easy to place the shoe onto the stitching area.

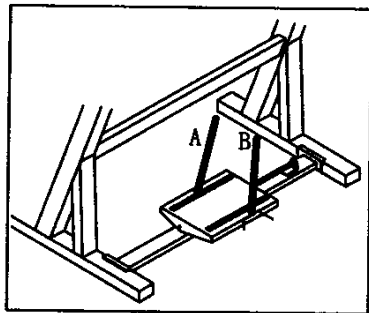

Fig 3

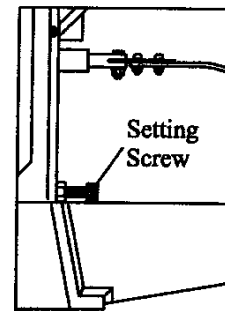

Fig 4

### 4.2 Stitching length adjustment setting

This setting is to determine the machine sewing stitch length or the distance between one stitch and the next.

To adjust stitching length , proceed as follows

- Turning the setting screw in a clockwise direction to reduce the stitching length(Fig 4) and turning the setting screw in a anti-clockwise direction to increase the stitching length.

### 4.3 Tension adjustment setting of needle thread

The setting is to adjust the needle thread tension so that the stitching on the leather is neither too tight nor too loose.

To set the needle thread tension , proceed as follows(Fig 5)

- Rotate the thread tension nut 1 in the clockwise direction will tighten the tension of the needle thread, and vice-versa.
- Loosen the nut 5 and turn the thread tack-up spring shaft in the anti-clockwise direction will increase the pressure of the tack-up spring , and vice-versa.
- Tighten the nut 5.

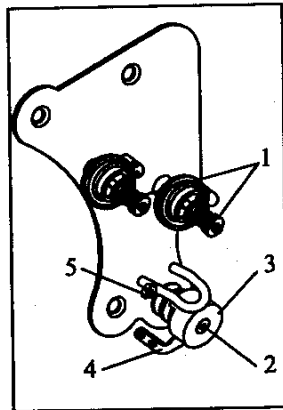

Fig 5

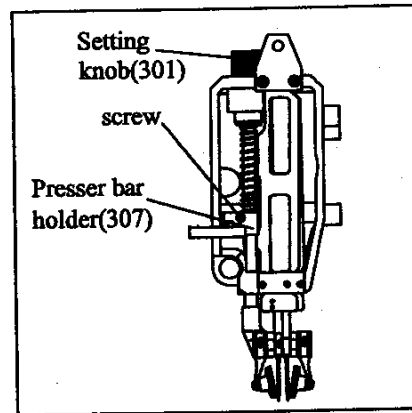

Fig 6

#### 4.4 Height adjustment setting of presser wheel (Fig 6)

The height of presser wheel can be adjusted by turning knob (301).

To set the height of presser wheel, proceed as follows

- Turning the knob(301) in the clockwise direction , the presser wheel(315) will be moved downward . And turning the knob(301) in the anti-clockwise direction , the presser wheel(315) will be moved upward.

#### 4.5 Pressure adjustment setting of presser wheel (Fig 6)

The pressure of presser wheel can be adjusted by moving presser bar holder's(307) position.

To set the pressure of presser wheel, proceed as follows

- Loosen the screws of the presser bar holder(307).
- moving the presser bar holder(307) upward will increase the pressure of the presser wheel(315) and moving presser bar holder(307) downward will reduce the pressure of the presser wheel(315).

## 5. REPLACEMENT AND ADJUSTMENT

### 5.1 Adjustment of the distance between two needles

There are two kinds of crank(236A/236B) can be used on GR-81, So that the distance between two needles can be 7.5mm or 5.5mm. The distance between two needles will be 7.5mm if the crank(236A) is used and The distance between two needles will be 5.5mm if the crank(236B) is used.

To replace the crank(236A/236B), proceed as follows(Fig 7)

- Loosen the screw 1 of the connecting lever(235) and screw 2 of the eccentric pin(238).
- Loosen the screws 3 of the crank(236A/236B).
- Remove the crank(236A/236B) from shaft (404).
- Fix another crank (236A/236B) on shaft(404).
- After replacement, fix all the parts that described above and tighten the screws again.

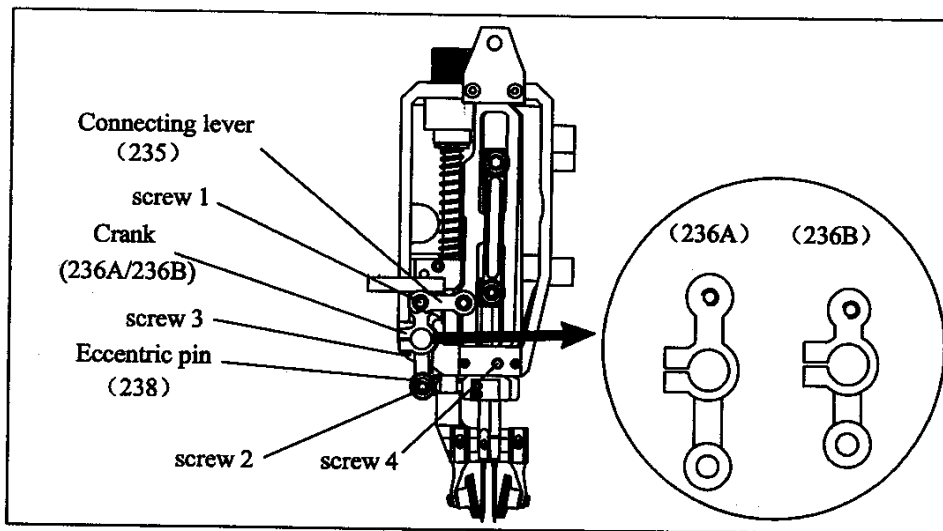

Fig 7

**Attention:** After replacement, rotate the pulley(203) by hand at least 4 circles to see if the distance between two needles is always same. If not, loosen the screw 3 of the crank(236A/236B) and rotate the crank(236A/236B) a little angles in the clockwise direction or in the anti-clockwise direction until the distance between two needles is always same before and after two needles be intercrossed.

### 5.2 Setting stitching seam

The operator can choose one of twelve stitching seams (six 1 needle and six 2 needles) as shown in the table 1. The stitching seam can be set by replace the cam(408) and cam(409).

To set stitching seam, the proceed as follows (Fig 8)

- Remove the side cover.
- Loosen the screws 1 of the lever(405) and remove the lever(405).
- Loosen the screws 2 of the cam(408).
- Remove the cam(408) and the cam(409).
- According to the stitching seam be required, choose the cam(408) and cam(409) as shown in the table 1 and fix them again.
- Fix the lever(405) and the sidecover again.

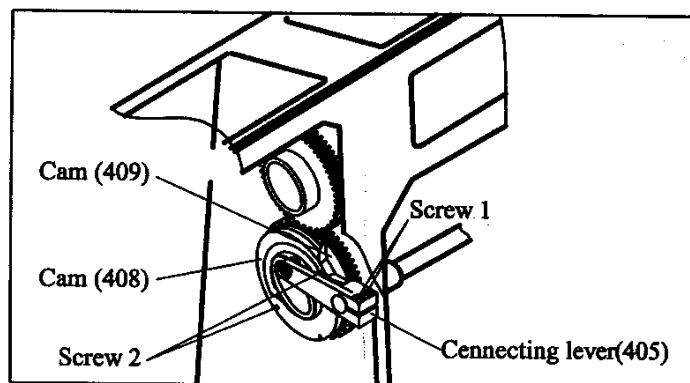

Fig 8











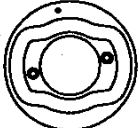



Stitching seam Cam 408	Cam 409	Cam 409A	Cam 409A	Cam 409A
	 Cam 408A	Fix 2 needles  Fix 1 needle 	Fix 2 needles  Fix 1 needle 	It is forbidden
 Cam 408B	Fix 2 needles  Fix 1 needle 	Fix 2 needles  Fix 1 needle 	Fix 1 needle  Fixing 2 needles is forbidden 	
Two Needle bars be not intercrossed	Fix 2 needles  Fix 1 needle 	It is forbidden	It is forbidden	

Table 1

To setting stitching seam as "Straight line", proceed as follows

- loosen the screw 3 (shown in Fig 7).
- Tighten the screw 4 (shown in Fig 7).
- Loosen nut 1 and screw 2, unconnecting the Connecting board (420) and the Pushing lever (421). (as shown in Fig 12)

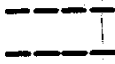
**Attention:** After setting the stitching seam, rotate the pulley (203) by hand at least 4 circles to see if the distance between two needles is always same. If not, loosen the screw 3 of the crank (236A/236B) and rotate the crank (236A/236B) a little angles in the clockwise direction or in the anti-clockwise direction until the distance between two needles is always same before and after two needles be intercrossed. (Fig 7)



### 5.3 Adjustment of setting the shuttle-needle timing

To adjust the shuttle-needle timing, proceed as follows(Fig 9)

- Loosen the screw 1 of the gear holder(518).
- Turn the pulley(203) by hand in the correct direction so that the needle comes to its lowest position. Thereafter, raise the needles by 5mm from the lowest position, and then adjust the shuttle so that the tip of shuttle turns across left needle (operator's side view) about 1mm and the tip of the shuttle is above the eye of the left needle about 2mm(Fig 10).
- After adjustment, tighten the screws 1 of the gear holder(518) again.

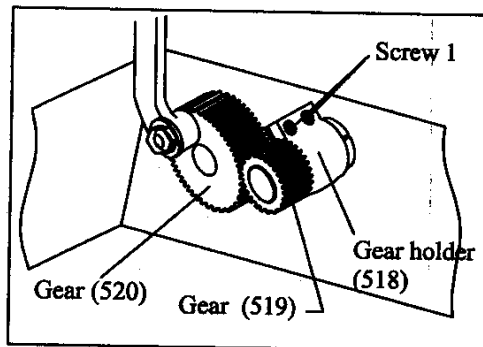

Fig 9

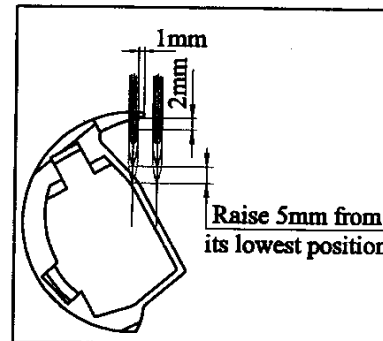

Fig 10

### 5.4 Adjustment of setting tooth transport

Turn the pulley(203) by hand in the correct direction so that the needle comes to its highest position. At the same time , the transport tooth moves to its highest and backest position(operator's side view), and beginning to move forward.

To adjust tooth transport, proceed as follows(Fig 11)

- Loosen the screws of the gear(209).
- Turn the gear(209) in the clockwise direction(operator's side view) , the timing of the transport movement will be faster . And vice-versa.
- Tighten the screws of gear(209) after adjustment.

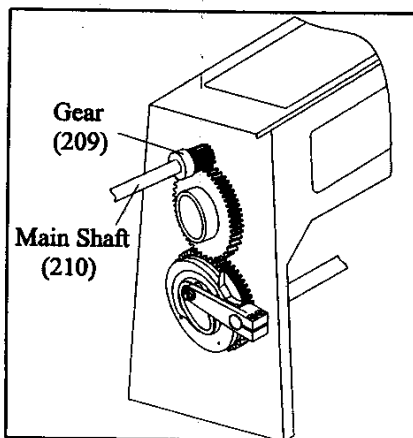

Fig 11

### 5.5 Adjustment of setting needles intercross timing

Turn the pulley(203) by hand in the correct direction so that the needle comes to its highest position. Then , two needles being crossed and stoped in the central line between two needles.

To adjust the needles intercross timing, proceed as described at 5.4(Fig11)

### 5.6 Adjustment of setting the distance of needle bar be pushed

Turn the pulley(203) by hand in the correct direction so that the needle comes to its highest position. Then , the back needle bar have pushed to its backest position(operator's side view) and the needle bars be knocked together should be avoided when they are intercrossing .

To set the distance of needle bar be pushed, proceed as follows(Fig 12)

- Turn the pulley(203) by hand in the correct direction so that the needle comes to its highest position .
- Loosen the nuts 1 and screws 2 of the connecting board(420).
- Move the pushing lever(421) towards operator will increase the distance of the needle bar be pushed , and vice-versa.
- Tighten the screws 2 and nut 1 of the connecting board(420) again.

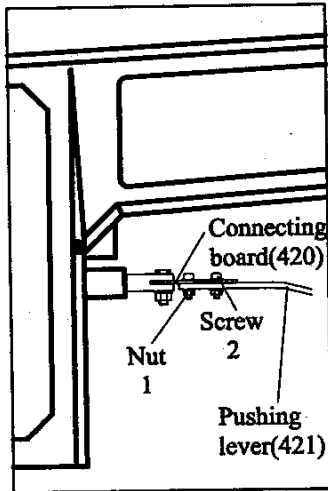

Fig 12

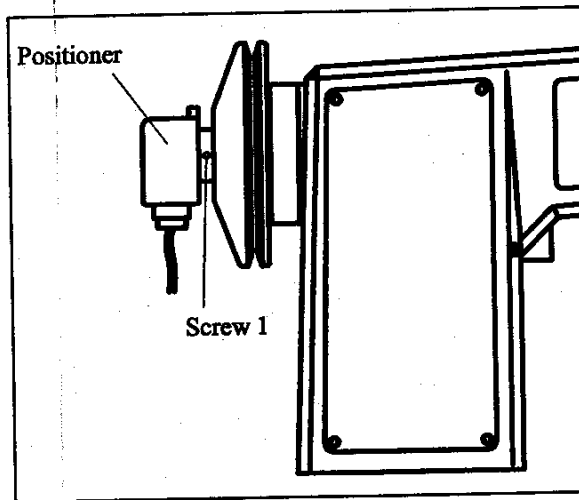

Fig 13

### 5.7 Adjustment of stopping position

The stopping position is used to control the pause position of the needle bar.

To adjust the stopping position , proceed as follows(Fig 13)

- Loosen the screw 1 of the positioner.
- Adjust the relative position between the positioner and the main shaft .
- After adjustment , tighten the screw 1 of the positioner again

## 6. MAINTENANCE AND REPAIR

The machine must be daily lubricated at the end of every shift. rotating parts and all lubricate eyes on the machine must be carefully and accurately lubricated daily. Always keep the machine clean and clean the presser wheel,shuttel and shuttle seat every shift.

Check and oil the machine carefully when it is reused after a long time. Test run and running slowly are required.

## 7. SPARE PARTS FOR THE SEWING MACHINE

Code number	Machine part	Quantity
236B	Crank	1
408A	Cam	1
409A	Cam	1
409C	Cam	1
514	Shuttle	1
515	Bobbin	2
542	Lug	1
	Needle	10

## 8. PARTS SUPPLIED WITH THE MACHINE

Part name	Quantity
Complete series of Allen wrenches (1.5mm-10mm)	1
T-Allen wrench (3mm)	1
T-Allen wrench (5mm)	1
Screwdriver (5x 200)	1
Crosswise screwdriver (5x 200)	1
Spanner (8/10mm)	1
Spanner (13/16mm)	1
Oiler	1
Thread wheel holder	1
Instruction manual	1

*OS 7200 DOUBLE NEEDLE LEVEL  
SEWING MACHINE*

*Parts  
Drawing*

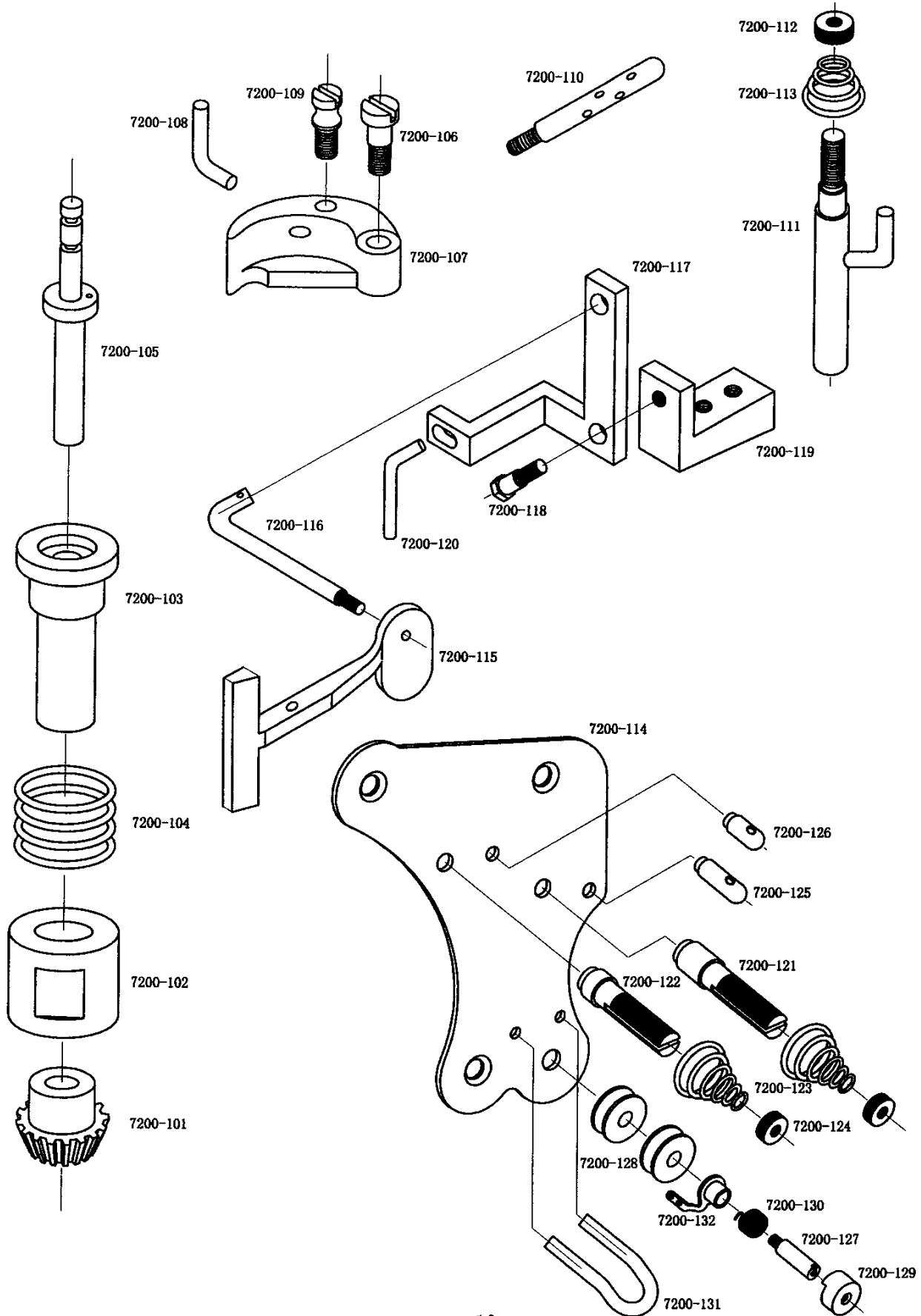

Fig.No.	Item	Quantity	Remarks
7200-101	Bevel gear	1	
7200-102	Fixed sleeve	1	
7200-103	Sleeve of the winding shaft	1	
7200-104	Clamping spring	1	
7200-105	Winding shaft	1	
7200-106	Screwing pin	1	
7200-107	Stopper	1	
7200-108	Stopper lever	1	
7200-109	Screw	1	
7200-110	Narrowing rod	1	
7200-111	Winding amount adjusting rod	1	
7200-112	Winding amount adjusting nut	1	
7200-113	Cone spring	1	
7200-114	Threading plate	1	
7200-115	Trigger piece of loosening thread	1	
7200-116	Connecting rod of loosening thread	1	
7200-117	Thread loosen lever	1	
7200-118	Screw pin of thread loosen lever	1	
7200-119	Support of thread loosen lever	1	
7200-120	Connecting rod	1	
7200-121	Rod of thread tighter(long)	1	
7200-122	Rod of thread tighter(short)	1	
7200-123	Cone spring	2	
7200-124	Nut	2	
7200-125	Thread guider rod(long)	1	
7200-126	Thread guider rod(short)	1	
7200-127	Thread take-up spring shaft	1	
7200-128	Threading wheel	2	
7200-129	Support	1	
7200-130	Torsion spring	1	
7200-131	Thread carrier	1	
7200-132	Thread take-up spring	1	

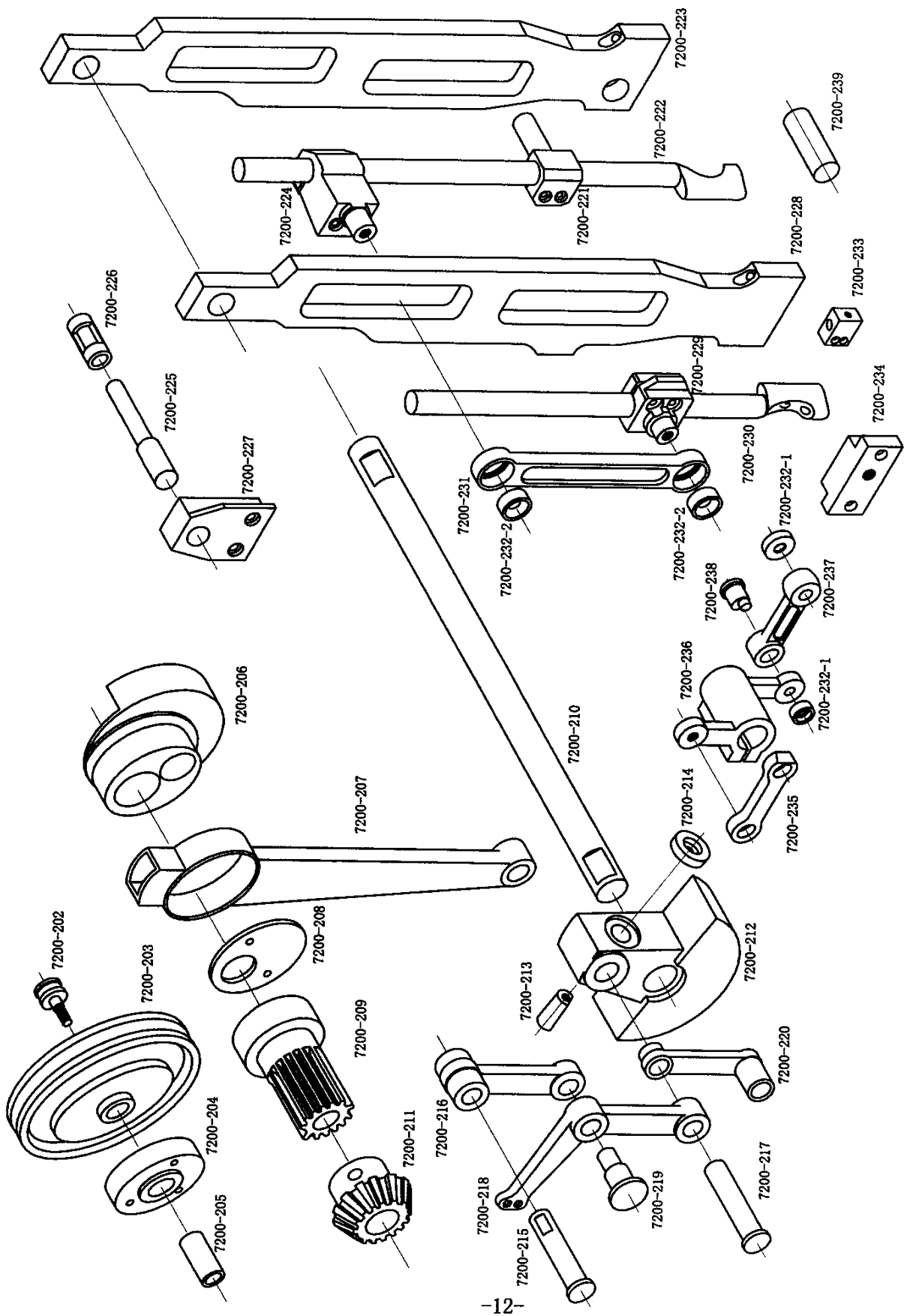
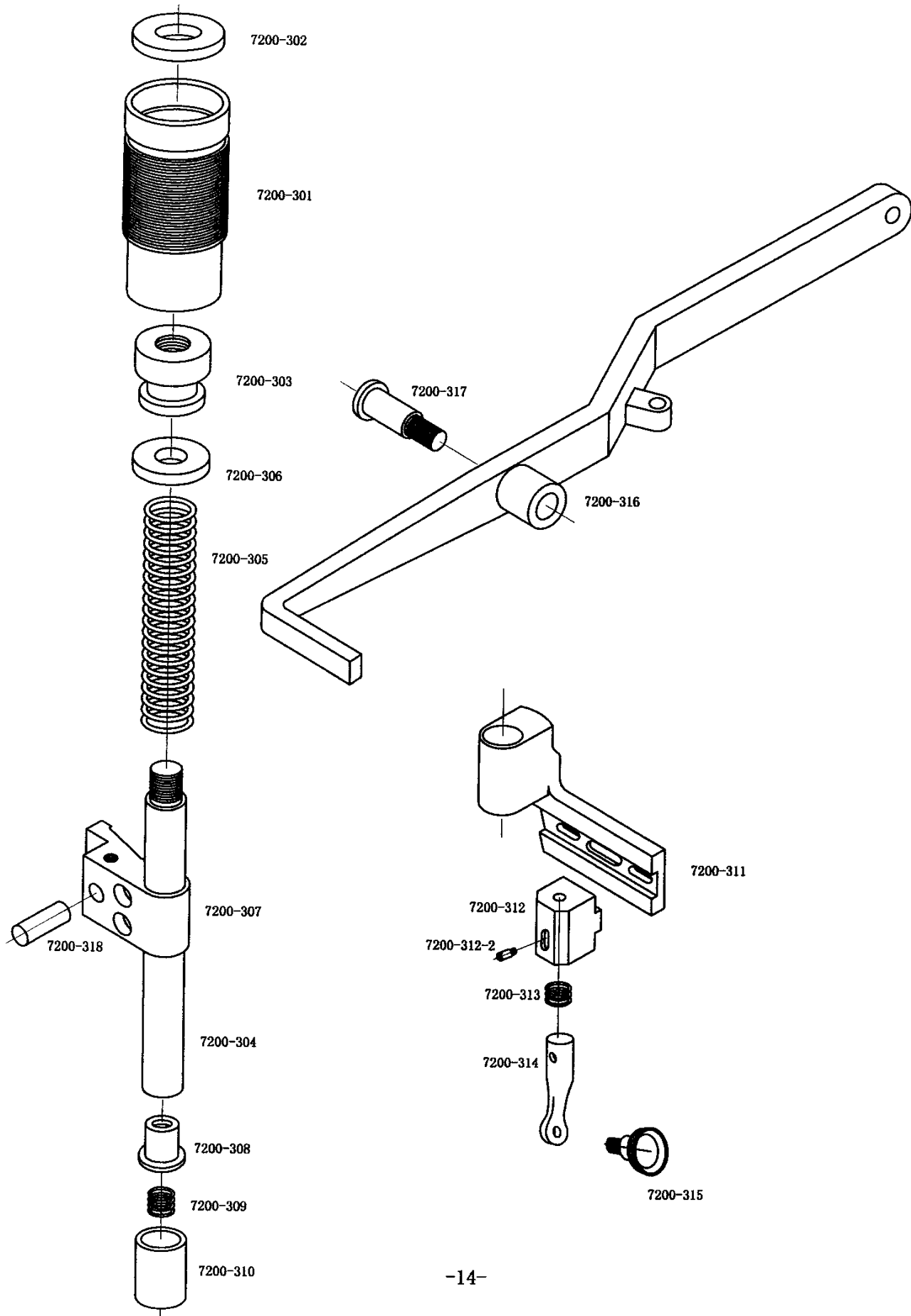
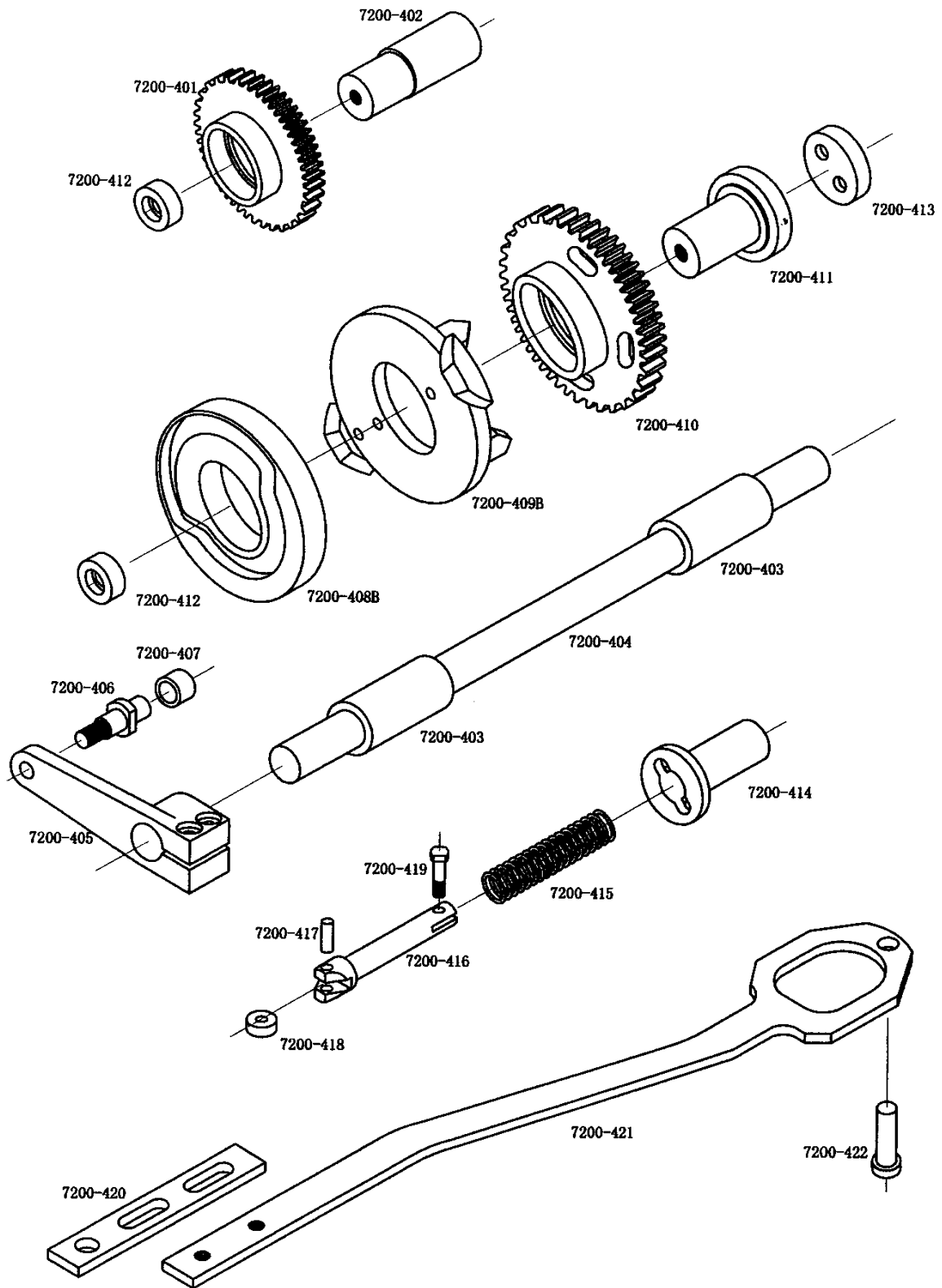

Fig.No.	Item	Quantity	Remarks
7200-201	Frame	1	
7200-202	Positioner support screw	1	
7200-203	Pulley	1	
7200-204	Bearing support	1	
7200-205	Sleeve	1	
7200-206	Eccentric gear of shuttle swing	1	
7200-207	Connecting lever	1	
7200-208	Cover plate	1	
7200-209	Gear	1	
7200-210	Main shaft	1	
7200-211	Bobbin thread winding gear	1	
7200-212	Crank of needle bar	1	
7200-213	Location pin	1	
7200-214	Washer	1	
7200-215	Pin of thread take-up crank	1	
7200-216	Connecting lever	1	
7200-217	Pin of connecting lever	1	
7200-218	Thread take-up lever	1	
7200-219	Connecting pin	1	
7200-220	Thread take-up connecting lever	1	
7200-221	Lower holder of back needle bar	1	
7200-222	Back needle bar	1	
7200-223	Back needle bar supporter	1	
7200-224	Higher holder of back needle bar	1	
7200-225	Pin of needle bar supporter	1	
7200-226	Sleeve	1	
7200-227	Support block of needle bar supporter	1	
7200-228	Fore needle bar supporter	1	
7200-229	Fore needle bar holder	1	
7200-230	Fore needle bar	1	
7200-231	Connecting lever of needle bar	1	
7200-232-1	Washer	2	
7200-232-2	Washer	2	
7200-233	Connecting block of push needle bar	1	
7200-234	Stopper block	1	
7200-235	Connecting lever	1	
7200-236	Crank	2	One is 236A and the other is 236B
7200-237	Connecting lever	1	
7200-238	Eccentric pin	1	
7200-239	Pin	1	











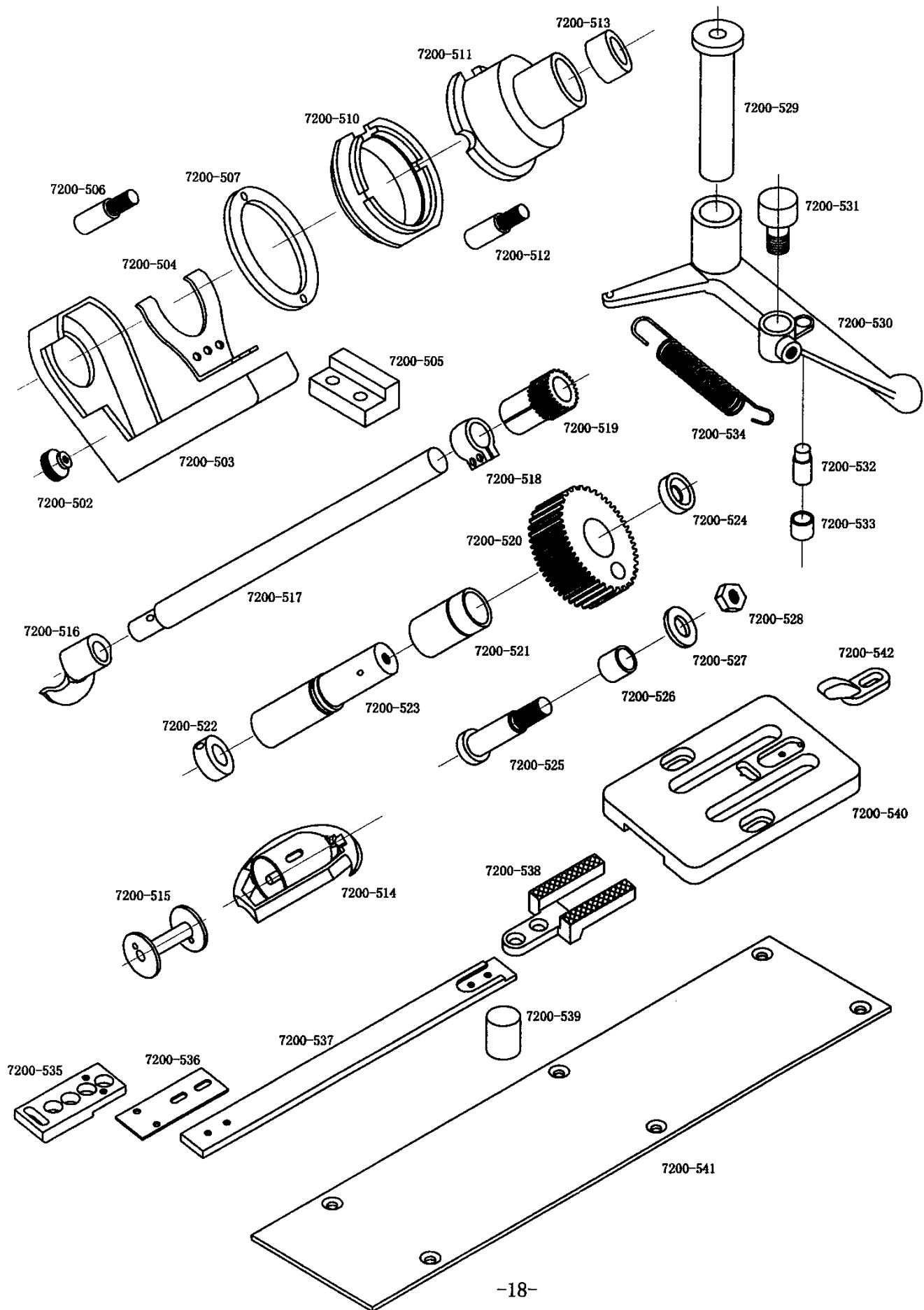

Fig.No.	Item	Quantity	Remarks
7200-501	Frame seat	1	
7200-502	Cupreous nut	1	
7200-503	Aluminic cover	1	
7200-504	Presser piece	1	
7200-505	Location block	1	
7200-506	Support pin	2	
7200-507	Cover ring	1	
7200-510	Outer shuttle seat	1	
7200-511	Inner shuttle seat	1	
7200-512	Location screw	2	
7200-513	Bearing washer	1	
7200-514	Shuttle	1	
7200-515	bobbin	2	
7200-516	Shuttle driver	1	
7200-517	Shuttle driver shaft	1	
7200-518	Gear holder	1	
7200-519	Droved gear	1	
7200-520	Driving gear	1	
7200-521	Sleeve	1	
7200-522	Lubricating ring	1	
7200-523	Eccentric shaft	1	
7200-524	Washer	1	
7200-525	Pin	1	
7200-526	Sleeve	1	
7200-527	Washer	1	
7200-528	Nut	1	
7200-529	Pin	1	
7200-530	Swing arm	1	
7200-531	Bearing	1	
7200-532	Roller pin	1	
7200-533	Roller	1	
7200-534	Spring	1	
7200-535	Transport block	1	
7200-536	Spring steel piece	1	
7200-537	Transport lever	1	
7200-538	Transport foot	1	
7200-539	Lifting block	1	
7200-540	Needle plate	1	
7200-541	Cover	1	
7200-542	Lug	1	